

SERIE 3

Per trattori 20-30 hp - For tractors 20-30 hp

RETROESCAVATORI
BACKHOES



3.15

Hobby e giardinaggio.
Hobby and gardening.

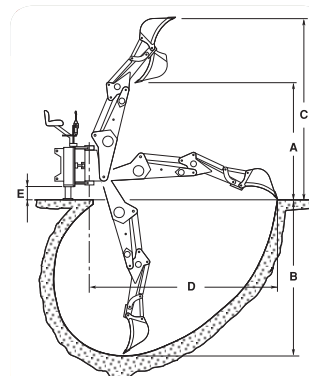

Serie 3	3.15
A (mm)	1.250
B (mm)	1.700
C (mm)	2.300
D (mm)	2.200
E (mm)	250

Modello Model	Profondità di scavo Digging depth (mm)	Angolo di rotazione Rotation angle	Larghezza telaio traslante Moving frame width (mm)	Peso Weight (kg)	Serbatoio Oil tank (L)	Benna da scavo Standard bucket (mm)	Forza di rottura al dente Tooth tearing resistance (kg)	Forza di scavo con braccio secondario Digging force with auxiliary boom (kg)
3.15	1.700	180°	1.100	285	15	250 (14 l)	1.500	700

CARATTERISTICHE TECNICHE E DOTAZIONI STANDARD

Retroescavatore traslabile con bloccaggio meccanico, applicabile all'attacco a tre punti del sollevatore idraulico.

Rotazione centrale a 180° con 1 martinetto (Brevetata)

Stabilizzatori idraulici indipendenti con valvole di blocco.

Impianto indipendente con pompa da 4 cm³/giro, moltiplicatore, serbatoio incorporato con capacità di 15 litri, filtro olio e olio idraulico.

Distributore monoblocco con portata di 40 litri/min e leve a cloche.

Portata d'olio 6 l/min.

Pressione massima di esercizio 190 bar.

Benna standard da 250 mm.

Articolazione con perni e boccole in acciaio cementato e temperato.

Steli dei martinetti cromati a doppio spessore.

Sabbatura e verniciatura con polveri poliestere.

Telaio irridigimento al trattore categoria 1

TECHNICAL FEATURES AND STANDARD EQUIPMENT

Sideshifting backhoe with mechanical locking, applicable to the three-point hitch of the hydraulic boom.

180° central rotation by 1 cylinder (patented).

Independent hydraulic stabilisers with block valves.

Independent system with 4 cm³/rev., pump, multiplier, 15-lt built-in tank, oil strainer and hydraulic oil.

Monoblock distributor with 40 lt/min flow rate and finger-tip control levers.

Flow rate 6 l/min.

Max working pressure: 190 bar.

Standard bucket: 250 mm.

Joints with pins and bushes of case-hardened and tempered steel.

Chrome-plated double-liner cylinder rods.

Sanding and polyester powder coating.

Stiffening tractor frame category 1

BENNA BUCKET	
250 mm	
300 mm	
400 mm	

BENNA PULIZIA FOSSI DITCH CLEANING BUCKET	
800 mm	

BENNA TRAPEZOIDALE TRAPEZOIDAL BUCKET	
550 mm	



Telaio irrigidimento al trattore
categoria 1 - Incluso

Stiffening tractor frame
category 1 - Included

SERIE 4

Per trattori 35-55 hp - For tractors 35-55 hp

RETROESCAVATORI
BACKHOES



4.21 1200	
4.21 1400	

Giardinaggio - Vigneto - Frutteto e manutenzione

Gardening - Wine growing - Horticulture and green maintenance

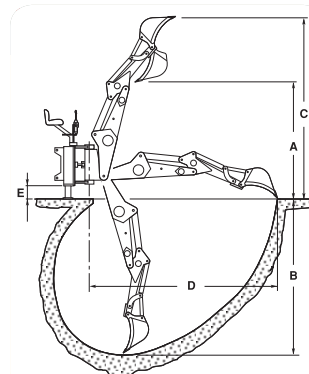

Serie 4	4.21
A (mm)	1.650
B (mm)	2.200
C (mm)	2.625
D (mm)	2.580
E (mm)	260

Modello Model	Profondità di scavo Digging depth (mm)	Angolo di rotazione Rotation angle	Larghezza telaio traslante Moving frame width (mm)	Peso Weight (kg)	Serbatoio Oil tank (L)	Benna da scavo Standard bucket (mm)	Forza di rottura al dente Tooth tearing resistance (kg)	Forza di scavo con braccio secondario Digging force with auxiliary boom (kg)
4.21 1.200	2.200	180°	1.200	375	22	300 (25 l)	2.200	1.000
4.21 1.400	2.200	180°	1.400	410	22	300 (25 l)	2.200	1.000

CARATTERISTICHE TECNICHE E DOTAZIONI STANDARD

Retroescavatore traslabile con bloccaggio idraulico, applicabile all'attacco a tre punti del sollevatore idraulico.

Rotazione centrale a 180° con 1 martinetto (Brevettata)

Stabilizzatori idraulici indipendenti con valvole di blocco.

Impianto indipendente con pompa da 8 cm³/giro, moltiplicatore, serbatoio incorporato con capacità di 22 litri, filtro olio e olio idraulico.

Distributore monoblocco con portata di 40 litri/min e leve a cloche.

Portata d'olio 15 l/min.

Pressione massima di esercizio 190 bar.

Benna standard da 300 mm.

Tenditori di bloccaggio bracci sollevatore.

Articolazioni con perni e boccole in acciaio cementato e temperato.

Steli dei martinetti cromati a doppio spessore.

Sabbiatura e verniciatura con polveri poliesteri.

Telaio irrigidimento al trattore categoria 1

TECHNICAL FEATURES AND STANDARD EQUIPMENT

Sideshifting backhoe with hydraulic locking, applicable to the three-point hitch of the hydraulic boom.

180° central rotation by 1 cylinder (patented).

Independent hydraulic stabilisers with block valves.

Independent system with 8 cm³/rev., pump, multiplier, 22-lit built-in tank, oil strainer and hydraulic oil.

Monoblock distributor with 40 lt/min flow rate and finger-tip control levers.

Flow rate 15 l/min.

Max working pressure: 190 bar.

Standard bucket: 300 mm.

Boom locking tensioners.

Joints with pins and bushes of case-hardened and tempered steel.

Chrome-plated double-liner cylinder rods.

Sanding and polyester powder coating.

Stiffening tractor frame category 1

ACCESSORI A RICHIESTA

- Impianto 1: benna orientabile Pulizia Fossi 45°.
- Impianto 2: predisposizione trinciatrice idraulica (include impianto 1). Pag. 88
- Decespugliatrice idraulica 800 mm T1 80 REV. Pag. 88
- Comando in cabina. Pag. 87
- Applicazione per minipale. Pag. 87
- Attacco pale articolate, terne, telescopici.

ACCESSORIES ON REQUEST

- Installation 1: ditch cleaning tilting buckets 45°.
- Installation 2: hydraulic mulcher (installation 1 included). Pag. 88
- Hydraulic mulcher 800 mm T1 80 REV. Pag. 88
- Remote control on the cab. Pag. 87
- Skid steer loader application. Pag. 87
- Hitch coupler for articulated backhoe-loaders, backhoe loaders, telescopic.

BENNA SCAVO BUCKET	
250 mm	
300 mm	
400 mm	
500 mm	
600 mm	

BENNA PULIZIA FOSSI DITCH CLEANING BUCKET	
800 mm	
1000 mm	
1200 mm	

BENNA ORIENTABILE 45° 45° TITLING BUCKET	
800 mm	
1000 mm	

BENNA TRAPEZOIDALE TRAPEZOIDAL BUCKET	
670 mm	



**Telaio irrigidimento al trattore
categoria 1 - Incluso**

*Stiffening tractor frame
category 1 - Included*

SERIE 5

Per trattori 55-90 hp - For tractors 55-90 hp

RETROESCAVATORI
BACKHOES



5.23

Semiprofessionale
Semiprofessional

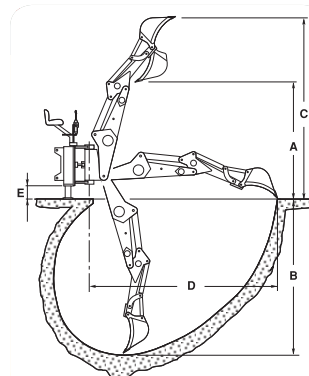

Serie 5	5.23
A (mm)	1.880
B (mm)	2.600
C (mm)	2.850
D (mm)	2.800
E (mm)	310

Modello Model	Profondità di scavo Digging depth (mm)	Angolo di rotazione Rotation angle	Larghezza telaio traslante Moving frame width (mm)	Peso Weight (kg)	Serbatoio Oil tank (L)	Benna da scavo Standard bucket (mm)	Forza di rottura al dente Tooth tearing resistance (kg)	Forza di scavo con braccio secondario Digging force with auxiliary boom (kg)
5.23	2.600	180°	1.500	580	35	300 (25 l)	2.800	1.100

CARATTERISTICHE TECNICHE E DOTAZIONI STANDARD

Retroescavatore traslabile con bloccaggio idraulico, applicabile all'attacco a tre punti del sollevatore idraulico.

Rotazione centrale a 180° con 1 martinetto (Brevetata)

Stabilizzatori idraulici indipendenti con valvole di blocco.

Impianto indipendente con pompa da 12 cm³/giro, moltiplicatore, serbatoio incorporato con capacità di 35 litri, filtro olio e olio idraulico.

Distributore monoblocco con portata di 40 litri/min e leve a cloche.

Portata d'olio 20 l/min.

Pressione massima di esercizio 190 bar.

Benna standard da 300 mm.

Tenditori di bloccaggio bracci sollevatore.

Articolazioni con perni e boccole in acciaio cementato e temperato.

Steli dei martinetti cromati a doppio spessore.

Sabbiatura e verniciatura con polveri poliestere.

Telaio irridigimento al trattore categoria 1 e 2.

TECHNICAL FEATURES AND STANDARD EQUIPMENT

Sideshifting backhoe with hydraulic locking, applicable to the three-point hitch of the hydraulic boom.

180° central rotation by 1 cylinder (patented).

Independent hydraulic stabilisers with block valves.

Independent system with 12 cm³/rev., pump, multiplier, 35-lt built-in tank, oil strainer and hydraulic oil.

Monoblock distributor with 40 lt/min flow rate and finger-tip control levers.

Flow rate 20 l/min.

Max working pressure: 190 bar.

Standard bucket: 300 mm.

Boom locking tensioners.

Joints with pins and bushes of case-hardened and tempered steel.

Chrome-plated double-liner cylinder rods.

Sanding and polyester powder coating.

Stiffening tractor frame category 1 and 2.

ACCESSORI A RICHIESTA

- Impianto 1: trivella, benna mordente, forca multiuso.
- Impianto 2: martello idraulico, benna orientabile Pulizia Fossi 45°, impianto rotatore idraulico + forca multiuso o benna mordente (include impianto 1).
- Impianto 3: decespugliatrice idraulica (include impianto 2). Pag. 88
- Decespugliatrice idraulica 800 mm T1 80 REV. Pag. 88
- Comando in cabina. Pag. 87
- Applicazione per minipale. Pag. 87
- Attacco pale articolate, terne, telescopici.

ACCESSORIES ON REQUEST

- Installation 1: auger, grab, multipurpose fork.
- Installation 2: hydraulic hammer, ditch cleaning titling buckets 45°, hydraulic rotator + multipurpose fork or Grab (installation 1 included).
- Installation 3: hydraulic mulcher (installation 2 included). Pag. 88
- Hydraulic mulcher 800 mm T1 80 REV. Pag. 88
- Remote control on the cab. Pag. 87
- Skid steer loader application. Pag. 87
- Hitch coupler for articulated backhoe-loaders, backhoe loaders, telescopic.

BENNA SCAVO BUCKET	
250 mm	
300 mm	
400 mm	
500 mm	
600 mm	

BENNA PULIZIA FOSSI DITCH CLEANING BUCKET	
800 mm	
1000 mm	
1200 mm	

BENNA ORIENTABILE 45° 45° TITLING BUCKET	
800 mm	
1000 mm	

BENNA TRAPEZOIDALE TRAPEZOIDAL BUCKET	
670 mm	

BENNA MORDENTE GRAB	
125 dm ³	



FORCA MULTIUSO MULTIPURPOSE FORK	
650 mm	

ROTATORE IDRAULICO HYDRAULIC ROTATOR	
BR10	

MARTELLLO IDRAULICO HYDRAULIC HAMMER	
62 kg	

TRIVELLA AUGER	
TR1	

COCLEE DRILL BITS (Ø x lg. 1000 mm)	
150	
200	
250	
300	
400	



Telaio irrigidimento al trattore categoria 1 e 2 - Incluso

Stiffening tractor frame category 1 and 2 - Included

SERIE 6

Per trattori 75-110 hp - For tractors 75-110 hp

RETROSCAVATORI
BACKHOES



6.28

Professionale
Professional

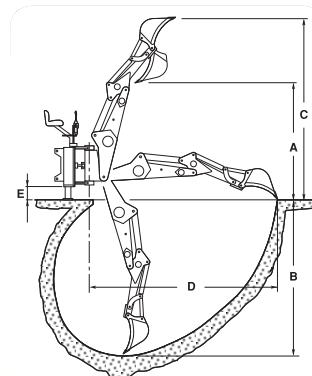

Serie 6	6.28
A (mm)	2.280
B (mm)	2.900
C (mm)	3.300
D (mm)	3.300
E (mm)	310

Modello Model	Profondità di scavo Digging depth (mm)	Angolo di rotazione Rotation angle	Larghezza telaio traslante Moving frame width (mm)	Peso Weight (kg)	Serbatoio Oil tank (L)	Benna da scavo Standard bucket (mm)	Forza di rottura al dente Tooth tearing resistance (kg)	Forza di scavo con braccio secondario Digging force with auxiliary boom (kg)
6.28	2.900	180°	1.700	730	45	300 (30 l)	3.500	1.600

CARATTERISTICHE TECNICHE E DOTAZIONI STANDARD

Retroescavatore traslabile con bloccaggio idraulico, applicabile all'attacco a tre punti del sollevatore idraulico.

Rotazione centrale a 180° con 1 martinetto (Brevettata)
Stabilizzatori idraulici indipendenti con valvole di blocco.

Impianto indipendente con pompa da 16 cm³/giro, moltiplicatore, serbatoio incorporato con capacità di 45 litri, filtro olio e olio idraulico.

Distributore ad elementi componibili con portata di 60 litri/min, valvole antiurto-anticavitazione incorporate.

Portata d'olio 25 l/min.

Pressione massima di esercizio 190 bar.

Benna standard da 300 mm.

Tenditori di bloccaggio bracci sollevatore.

Articolazioni con perni e boccole in acciaio cementato e temperato.

Steli dei martinetti cromati a doppio spessore.

Sabbiatura e verniciatura con polveri poliesteri.

Telaio irrigidimento al trattore categoria 1 e 2.

TECHNICAL FEATURES AND STANDARD EQUIPMENT

Sideshifting backhoe with hydraulic locking, applicable to the three-point hitch of the hydraulic boom.

180° central rotation by 1 cylinder (patented).

Independent hydraulic stabilisers with block valves.

Independent system with 16 cm³/rev., pump, multiplier, 45-lt built-in tank, oil strainer and hydraulic oil.

Element distributor with 60 lt/min flow rate and finger-tip control levers and built-in shock-absorbing anti-cavitation valves.

Flow rate 25 l/min.

Max working pressure: 190 bar.

Standard bucket: 300 mm.

Boom locking tensioners.

Joints with pins and bushes of case-hardened and tempered steel.

Chrome-plated double-liner cylinder rods.

Sanding and polyester powder coating.

Stiffening tractor frame category 1 and 2.

ACCESSORI A RICHIESTA

- Impianto 1: trivella, benna mordente, forca multiuso.
- Impianto 2: martello idraulico, benna orientabile Pulizia Fossi 45°, impianto rotatore idraulico + forca multiuso o benna mordente (include impianto 1).
- Impianto 3: decespugliatrice idraulica (include impianto 2). Pag. 88
- Decespugliatrice idraulica 800 mm T1 80 REV. Pag. 88
- Comando in cabina. Pag. 87
- Applicazione per minipale. Pag. 87
- Attacco pale articolate, terne, telescopici.

ACCESSORIES ON REQUEST

- Installation 1: auger, grab, multipurpose fork.
- Installation 2: hydraulic hammer, ditch cleaning titling buckets 45°, hydraulic rotator + multipurpose fork or Grab (installation 1 included).
- Installation 3: hydraulic mulcher (installation 2 included). Pag. 88
- Hydraulic mulcher 800 mm T1 80 REV. Pag. 88
- Remote control on the cab. Pag. 87
- Skid steer loader application. Pag. 87
- Hitch coupler for articulated backhoe-loaders, backhoe loaders, telescopic.

BENNA SCAVO BUCKET	
250 mm	
300 mm	
400 mm	
500 mm	
600 mm	
700 mm	

BENNA PULIZIA FOSSI DITCH CLEANING BUCKET	
800 mm	
1000 mm	
1200 mm	

BENNA ORIENTABILE 45° 45° TITLING BUCKET	
1000 mm	
1200 mm	

BENNA TRAPEZOIDALE TRAPEZOIDAL BUCKET	
740 mm	

BENNA MORDENTE GRAB	
175 dm ³	



FORCA MULTIUSO MULTIPURPOSE FORK	
800 mm	

ROTATORE IDRAULICO HYDRAULIC ROTATOR	
BR35	

MARTELLO IDRAULICO HYDRAULIC HAMMER	
96 kg	

TRIVELLA AUGER	
TR2	

COCLEE DRILL BITS (Ø x lg.1000 mm)	
150	
200	
250	
300	
400	



Telaio irrigidimento al trattore categoria 1 e 2 - Incluso

Stiffening tractor frame category 1 and 2 - Included

SERIE 7

Per trattori 100-200 hp - For tractors 100-200 hp

RETROSCAVATORI
BACKHOES



7.32

Semi-industriale
Semi-industrial

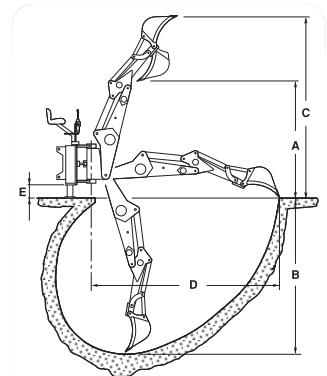

Serie 7	7.32
A (mm)	2.490
B (mm)	3.300
C (mm)	3.675
D (mm)	3.700
E (mm)	310

Modello Model	Profondità di scavo Digging depth (mm)	Angolo di rotazione Rotation angle	Larghezza telaio traslante Moving frame width (mm)	Peso Weight (kg)	Serbatoio Oil tank (L)	Benna da scavo Standard bucket (mm)	Forza di rottura al dente Tooth tearing resistance (kg)	Forza di scavo con braccio secondario Digging force with auxiliary boom (kg)
7.32	3.300	180°	2.000	1.080	60	300 (30 l)	4.200	1.850

CARATTERISTICHE TECNICHE E DOTAZIONI STANDARD

Retroescavatore traslabile con bloccaggio idraulico, applicabile all'attacco a tre punti del sollevatore idraulico.

Rotazione centrale a 180° con 1 martinetto (Brevettata)

Stabilizzatori idraulici indipendenti con valvole di blocco.

Impianto indipendente con pompa da 27 cm³/giro, moltiplicatore, serbatoio incorporato con capacità di 60 litri, filtro olio e olio idraulico.

Distributore ad elementi componibili con portata di 60 litri/1', leve a cloche, valvole antiurto-anticavitazione incorporate.

Portata d'olio 45 l/min.

Pressione massima di esercizio 190 bar.

Benna standard da 300 mm.

Tenditori di bloccaggio bracci sollevatore.

Articolazioni con perni e boccole in acciaio cementato e temperato.

Steli dei martinetti cromati a doppio spessore.

Sabbiatura e verniciatura con polveri poliesteri.

Telaio irrigidimento al trattore categoria 1 e 2.

TECHNICAL FEATURES AND STANDARD EQUIPMENT

Sideshifting backhoe with hydraulic locking, applicable to the three-point hitch of the hydraulic boom.

180° central rotation by 1 cylinder (patented).

Independent hydraulic stabilisers with block valves.

Independent system with 27 cm³/rev., pump, multiplier, 60-lt built-in tank, oil strainer and hydraulic oil.

Element distributor with 60 lt/1' flow rate, control levers and built-in shock-absorbing anti-cavitation valves.

Flow rate 45 l/min.

Max working pressure: 190 bar.

Standard bucket: 300 mm.

Boom locking tensioners.

Joints with pins and bushes of case-hardened and tempered steel.

Chrome-plated double-liner cylinder rods.

Sanding and polyester powder coating.

Stiffening tractor frame category 1 and 2.

ACCESSORI A RICHIESTA

- Impianto 1: trivella, benna mordente, forca multiuso.
- Impianto 2: martello idraulico, benna orientabile Pulizia Fossi 45°, impianto rotatore idraulico + forca multiuso o benna mordente (include impianto 1).
- Impianto 3: decespugliatrice idraulica (include impianto 2). Pag. 88
- Decespugliatrice idraulica 800 mm T1 80 REV. Pag. 88
- Comando in cabina. Pag. 87
- Applicazione per minipale. Pag. 87
- Attacco pale articolate, terne, telescopici.

ACCESSORIES ON REQUEST

- Installation 1: auger, grab, multipurpose fork.
- Installation 2: hydraulic hammer, ditch cleaning titling buckets 45°, hydraulic rotator + multipurpose fork or Grab (installation 1 included).
- Installation 3: hydraulic mulcher (installation 2 included). Pag. 88
- Hydraulic mulcher 800 mm T1 80 REV. Pag. 88
- Remote control on the cab. Pag. 87
- Skid steer loader application. Pag. 87
- Hitch coupler for articulated backhoe-loaders, backhoe loaders, telescopic.

BENNA SCAVO BUCKET	
250 mm	
300 mm	
400 mm	
500 mm	
600 mm	
700 mm	

BENNA PULIZIA FOSSI DITCH CLEANING BUCKET	
800 mm	
1000 mm	
1200 mm	

BENNA ORIENTABILE 45° 45° TITLING BUCKET	
1000 mm	
1200 mm	

BENNA TRAPEZOIDALE TRAPEZOIDAL BUCKET	
740 mm	

BENNA MORDENTE GRAB	
175 dm ³	



FORCA MULTIUSO MULTIPURPOSE FORK	
800 mm	

ROTATORE IDRAULICO HYDRAULIC ROTATOR	
BR35	

MARTELLO IDRAULICO HYDRAULIC HAMMER	
96 kg	

TRIVELLA AUGER	
TR2	

COCLEE DRILL BITS (Ø x lg.1000 mm)	
150	
200	
250	
300	
400	



Telaio irrigidimento al trattore categoria 1 e 2 - Incluso

Stiffening tractor frame category 1 and 2 - Included

SERIE 7S

Per trattori 120-200 hp - For tractors 120-200 hp

RETROSCAVATORI
BACKHOES



7S

Industriale
Industrial

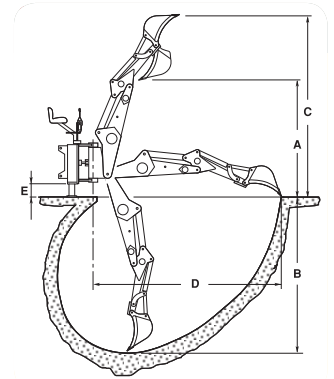

Serie 7S	
A (mm)	3.780
B (mm)	4.650
C (mm)	4.820
D (mm)	5.210
E (mm)	310

Modello Model	Profondità di scavo Digging depth (mm)	Angolo di rotazione Rotation angle	Larghezza telaio traslante Moving frame width (mm)	Peso Weight (kg)	Serbatoio Oil tank (L)	Benna da scavo Standard bucket (mm)	Forza di rottura al dente Tooth tearing resistance (kg)	Forza di scavo con braccio secondario Digging force with auxiliary boom (kg)
7S	4.650	180°	2.000	1.190	60	300 (30 l)	5.135	1.800

CARATTERISTICHE TECNICHE E DOTAZIONI STANDARD

Retroscavatore traslabile con bloccaggio idraulico, applicabile all'attacco a tre punti del sollevatore idraulico.

Rotazione centrale a 180° con 1 martinetto (Brevettata)

Stabilizzatori idraulici indipendenti con valvole di blocco.

Impianto indipendente con pompa da 44 cm³/giro, moltiplicatore, serbatoio incorporato con capacità di 60 litri, filtro olio e olio idraulico.

Distributore ad elementi componibili con portata di 60 litri/1', leve a cloche, valvole antiurto-anticavitazione incorporate.

Portata d'olio 70 l/min.

Pressione massima di esercizio 190 bar.

Benna standard da 300 mm.

Tenditori di bloccaggio bracci sollevatore.

Articolazioni con perni e boccole in acciaio cementato e temperato.

Steli dei martinetti cromati a doppio spessore.

Sabbatura e verniciatura con polveri poliestere.

Telaio irridimento al trattore categoria 1 e 2.

TECHNICAL FEATURES AND STANDARD EQUIPMENT

Sideshifting backhoe with hydraulic locking, applicable to the three-point hitch of the hydraulic boom.

180° central rotation by 1 cylinder (patented).

Independent hydraulic stabilisers with block valves.

Independent system with 44 cm³/rev., pump, multiplier, 60-lt built-in tank, oil strainer and hydraulic oil.

Element distributor with 60 lt/1' flow rate, control levers and built-in shock-absorbing anti-cavitation valves.

Flow rate 70 l/min.

Max working pressure: 190 bar.

Standard bucket: 300 mm.

Boom locking tensioners.

Joints with pins and bushes of case-hardened and tempered steel.

Chrome-plated double-liner cylinder rods.

Sanding and polyester powder coating.

Stiffening tractor frame category 1 and 2.

ACCESSORI A RICHIESTA

- Impianto 1: trinciatrice idraulica. Pag. 88
- Decespugliatrice idraulica 800 mm T1 80 REV. Pag. 88

ACCESSORIES ON REQUEST

- Installation 1: hydraulic mulcher. Pag. 88
- Hydraulic mulcher 800 mm T1 80 REV. Pag. 88

EQUIPAGGIAMENTO SPECIALE

- Equipaggiamento speciale: pompa maggiorata 70 l/min, deviatore elettrico, distributore 8 elementi, due linee aggiuntive da 1/2" in punta al braccio.

SPECIAL EQUIPMENT

- Special equipment: upgrated pump 70 l/min, electric switch, distributor with 8 elements, two 1/2" additional lines at the jib end.

BENNA SCAVO BUCKET	
250 mm	
300 mm	
400 mm	
500 mm	
600 mm	
700 mm	

BENNA PULIZIA FOSSI DITCH CLEANING BUCKET	
800 mm	
1000 mm	
1200 mm	

BENNA ORIENTABILE 45° 45° TITLING BUCKET	
1000 mm	
1200 mm	

BENNA TRAPEZOIDALE TRAPEZOIDAL BUCKET	
740 mm	

BENNA MORDENTE GRAB	
175 dm ³	



FORCA MULTIUSO MULTIPURPOSE FORK	
800 mm	

ROTATORE IDRAULICO HYDRAULIC ROTATOR	
BR35	

MARTELLO IDRAULICO HYDRAULIC HAMMER	
96 kg	

TRIVELLA AUGER	
TR2	

COCLEE DRILL BITS (Ø x lg.1000 mm)	
150	
200	
250	
300	
400	

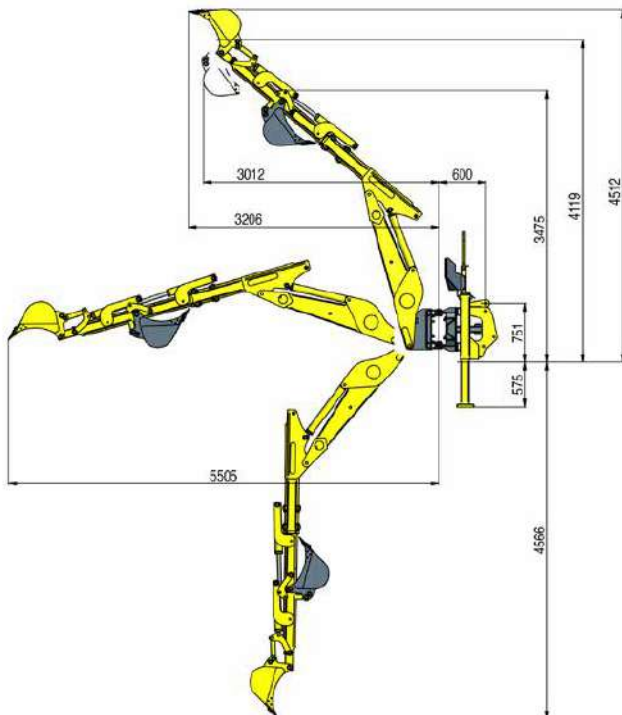

Telaio irrigidimento al trattore categoria 1 e 2 - Incluso

Stiffening tractor frame category 1 and 2 - Included